

## Park Farmhouse, Hoxne, Suffolk



South front of Park Farmhouse

Park Farmhouse is a medieval two storey timber framed building that was built as a standing for viewing the deer in the medieval park which surrounds the building. It is 46ft by 21½ft on the ground floor, and jettied to the south front. The first floor seems to have been one single room, very tall and open to the roof with an unusual 4 bay bay structure. The west bay AB is 8ft long, then BC 9½ft, CD 17ft and the east bay DE 10½ft. The ground floor appears to have had a long east west partition creating a 5ft wide corridor along the south side of the building as shown on the reconstruction plan.

One difficulty with interpreting this building is that very little of the timber framing is visible on the ground floor, apart from the ceiling in the eastern half. The ceiling in the western half has been rebuilt. The east-west partition probably continued though the western half, but one can not be certain as no other building has been recorded with this layout. More is visible on the first floor, showing all four trusses were open to form a single room, and the beautiful roof survives intact. It is a double tier queen post roof with a crownpost rising above the queenpost collar.

In the 17th century a back-to-back pair of fireplaces were inserted on the south side of truss DD' with, what was possibly the original medieval entrance in the south front, being retained, but now opening into the lobby on the side of the inserted chimney stack, creating a lobby entrance house. Stairs were added on the north side of the chimney stack, probably a circular stairs. They have since been made straighter up to the first floor, but circular stairs survive continuing from the first floor up to the attic. Partitions were added on both the ground and first floors to create three rooms on each floor. Part of the collar purlin was removed to make way for the inserted chimney and an additional queenpost was added against the west side of the stack to support the collar purlin. This was made of re-used timber including a crenellated beam being used for the collar. Late an outshot was added along the north side and additions made to the outshot in the 20th century.

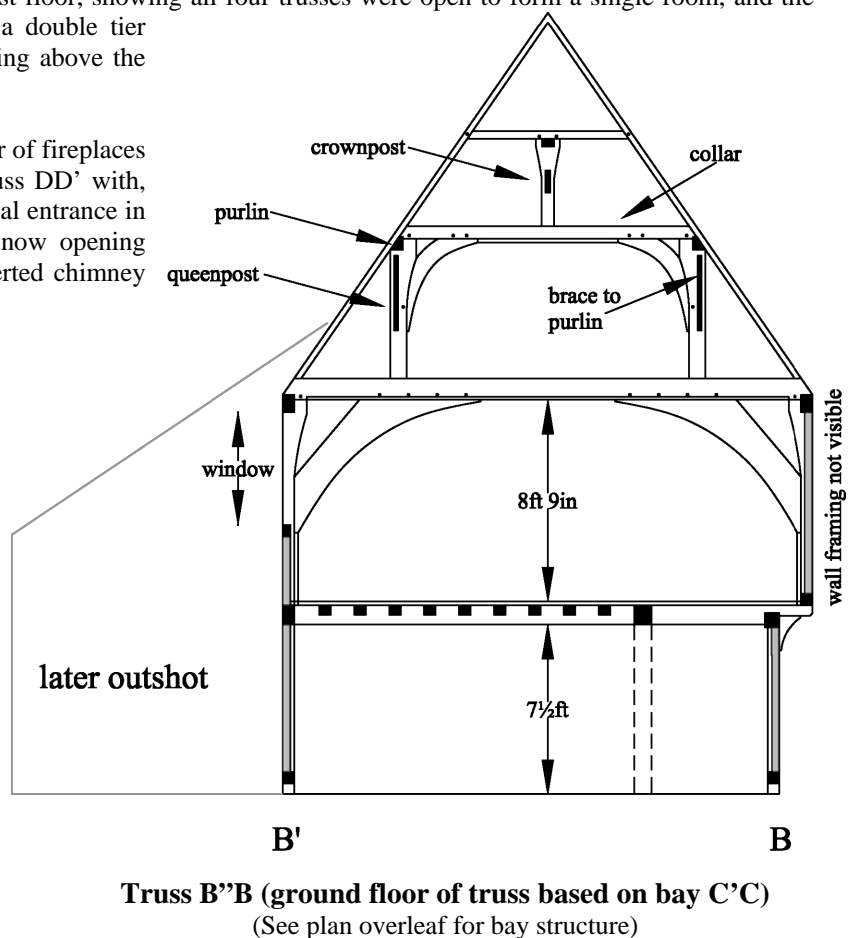

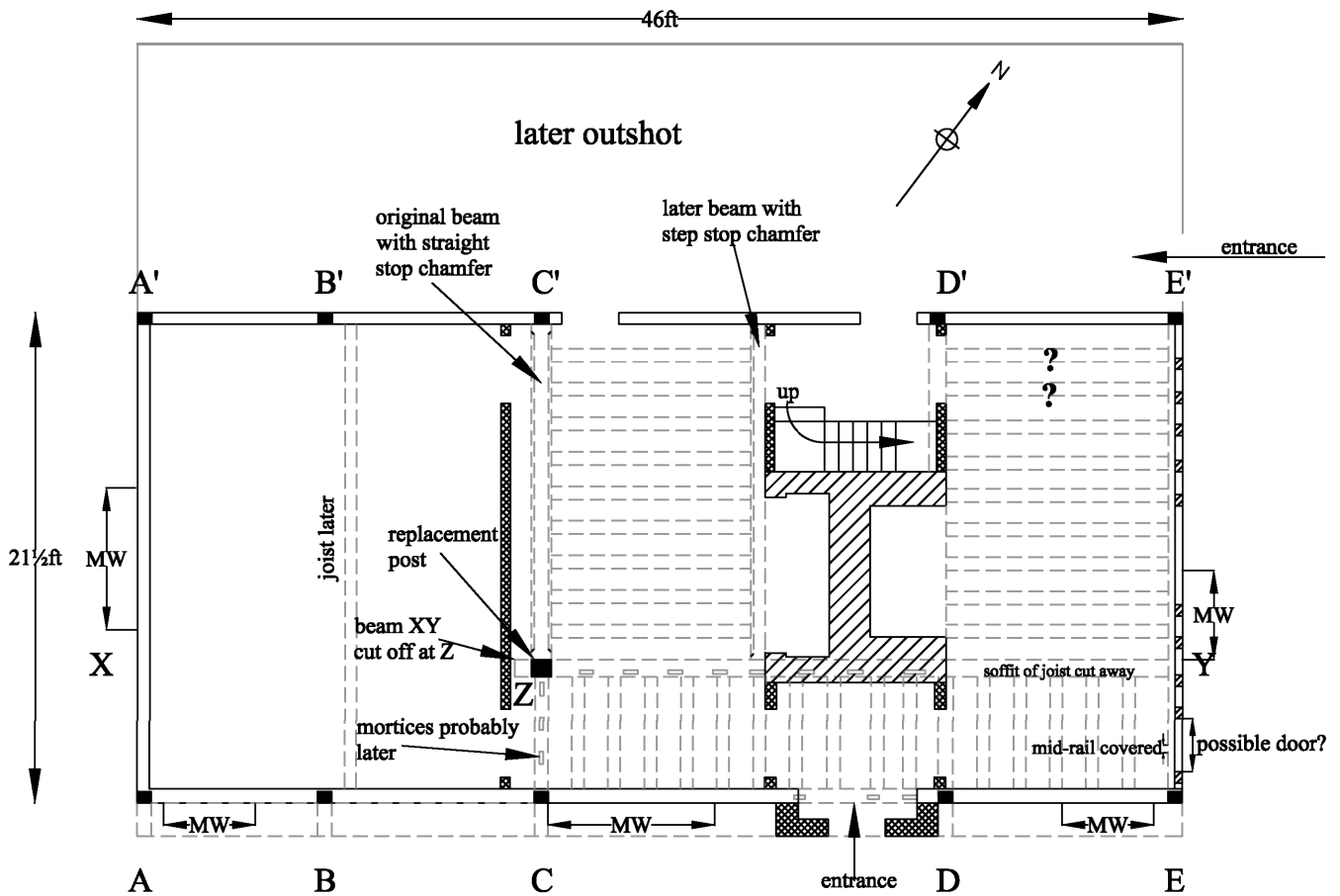

**Ground plan today - converted in 17th century into lobby entrance house**

Window 1st fl 2ft 5in wide    Window 1st fl 2ft 7in wide

Approximate Scale    Copyright John Walker June 2018

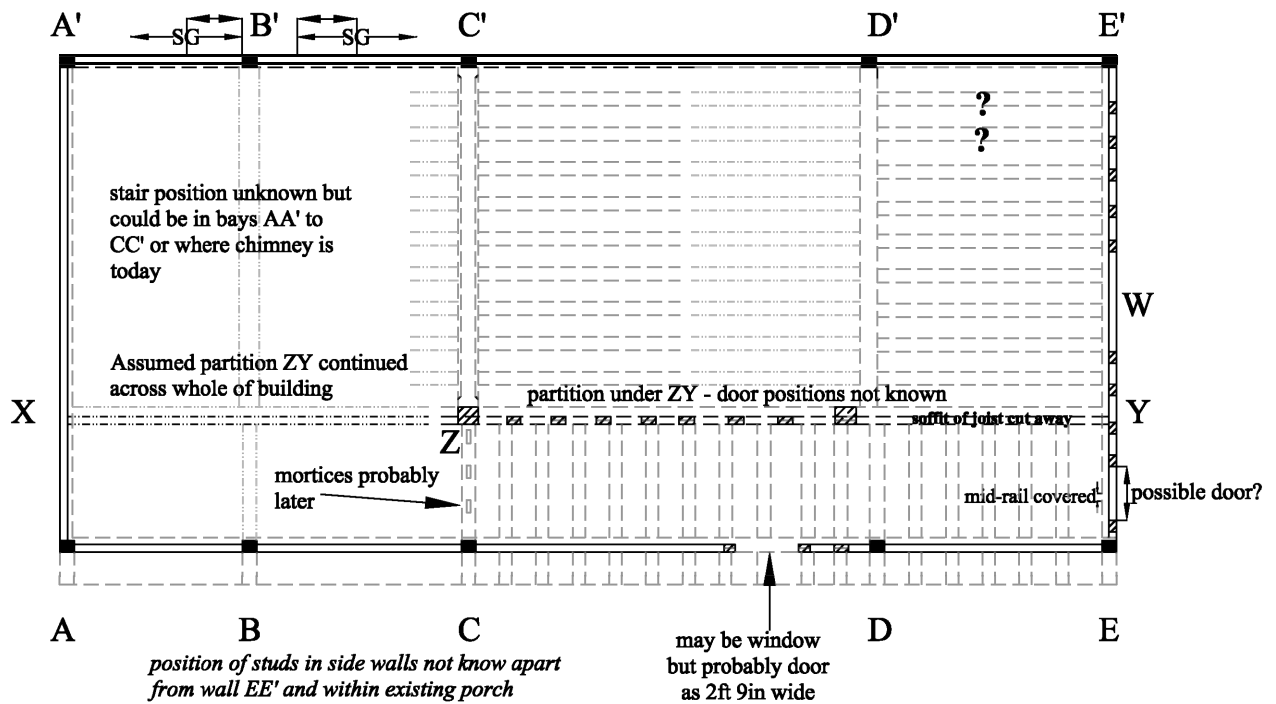

**Reconstruction of Ground plan when built in 15th century**

- ▨ = later and modern partitions
- ▤ = studs missing or not visible
- = original joists
- - - = joists that are hypothetical
- MW = modern windows
- W = medieval windows
- SG = shutter groove

## Ground plan of Park Farmhouse, Hoxne, Suffolk

Map ref: TM203751



Two tier queenpost roof with crownpost above looking east to inserted chimney



Additional queenpost truss inserted in 17th century to support truncated collar purlin with a re-used crenellated beam for the collar

## 17th Century Barn at Park Farm, Hoxne, Suffolk

To the south of the farmhouse is complex of barns forming a 'T' shape extending to the north with lower buildings behind on the south side (Fig 1). The top of the 'T' running west to east is a 17th century barn with jowled posts and drooping braces (Fig 2) and face halved and bridled scarf joints (Fig 3), the type that became the main scarf joint from the 17th century onwards.

Unfortunately it is not safe to see the upper part of the barn in Fig 2, but parts of the framing are visible in the east end (that to the left of the brick wing in Fig 1).

On the rear south wall part of the wattle and daub infill survives (Fig 4). The exterior was completely plastered over by nailing horizontal laths to the exterior of the studs as in Fig 4, with vertical wattle rods fitted between the studs and tied to the laths. The daub was then applied to the exterior covering the studs and laths while, on the interior, the daub was applied to the vertical rods between the studs, leaving the studs visible internally. As can be seen there are no marks on the side of the studs and, where the exterior covering has been removed there is no visible evidence of there having been wattle and daub infilling between the studs.

On buildings where the studs are exposed externally, horizontal rods are jammed between the studs to which the verticals are tied. When removed the wattle leaves marks in the side of the studs indicating where the horizontal rods were fitted.

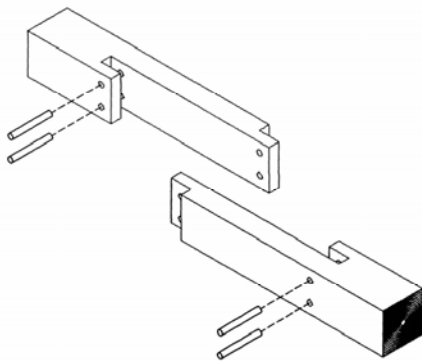

Fig 3: Face halved and bridled scarf joint (this joint appears in the late 16th century, but comes into common use from the second quarter of the 17th C)



Fig 1: North front of barn complex at Park Farm, Hoxne



Fig 2: North-west corner of 17th century barn



Fig 4: Exterior of east end of south wall of 17th C barn